

# User Manual

**E20 SPORT Walk-Behind Scrubber  
Disc Traction Drive**

Please see page 8  
for important information  
about the 172520-8 Surface Prep Pads  
included with this machine.

## Technical Specifications

This manual provides the necessary operating and preventive maintenance instructions. Operators must read and understand this manual before operating or servicing this machine.

This machine was designed to give you excellent performance and efficiency. For best results and minimal cost, please follow the general guidelines below:

- Operate the machine with reasonable care.
- Follow the manufacturer's suggested maintenance instructions as provided in this booklet.
- Use original Minuteman supplied parts.

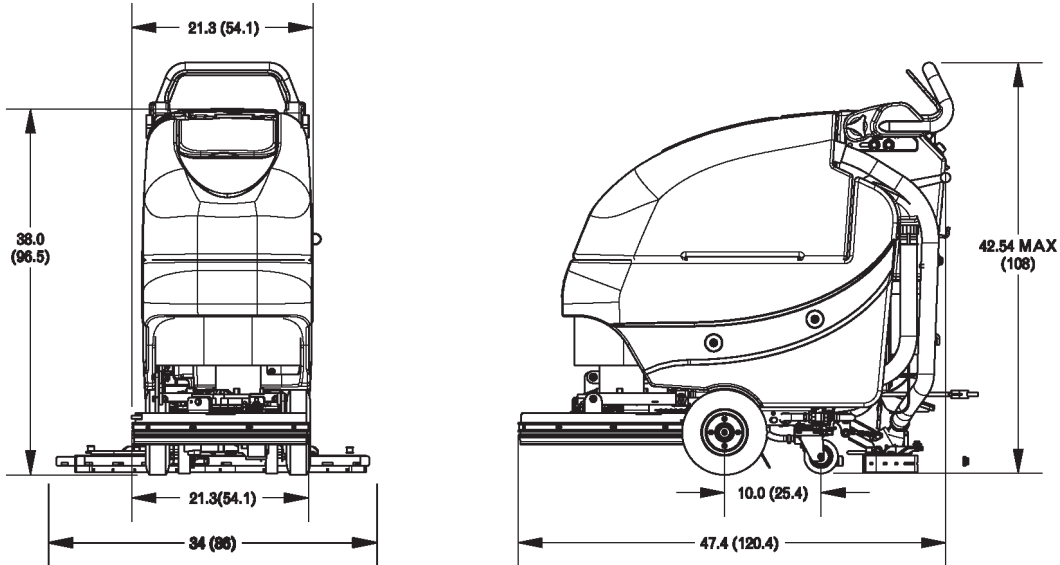

in (cm)

**Model** *E20 SPORT Traction Drive*

**Model No.** E20S, E20SQP, E20SQPG

<b>Current (Max)</b>	32/40 amps
<b>Battery Capacity (Lead Acid)</b>	140Ah @20 hr
<b>Battery Capacity (Gel)</b>	140Ah @20 hr
<b>Sound Level</b>	69 dBA
<b>Cleaning path width</b>	20 in (51 cm)
<b>Squeegee width</b>	34 in (86 cm)
<b>Productivity (Traction Drive)</b>	27,280 ft <sup>2</sup> /hr ( 2,534 m <sup>2</sup> )
<b>Working speed (Traction Drive)</b>	3.1 mph (5 km per hr)
<b>Transport Speed</b>	3 mph (4.8 km per hr)
<b>Rated voltage</b>	24 volts
<b>Vacuum flow</b>	65 cfm (110 m3/hr)
<b>Vacuum waterlift</b>	45 inches ( 112mbar)
<b>Vacuum power</b>	.60 HP (450 W)
<b>Brush type</b>	Disc
<b>Brush motor(s) power</b>	1 HP (750W)
<b>Number of brushes</b>	1
<b>Brush RPM</b>	180 RPM (LOW) / 370 RPM (HIGH)
<b>Aqua-Stop equipped</b>	Optional
<b>Solution capacity</b>	12 Gal (45 liters)
<b>Recovery capacity</b>	13 Gal (49 liters)
<b>Working Grade</b>	2%
<b>Weight with batteries</b>	380 lbs (169 kg)
<b>Weight without batteries</b>	240 lbs (108 kg)
<b>Dimensions (LxWxH)</b>	47.4 x 21.3 x 42.3 (120.4 x 54.1 107.4 cm)
<b>Drive Motor Power</b>	1/5 HP (150W)



<b>Safety Instructions</b> .....	<b>6</b>	Solution Fill Filter .....	21
<b>Unpacking Instructions</b> .....	<b>7</b>	Screened Float .....	22
Inspection .....	7	Screened Float Removal .....	22
Electrical .....	7	Recovery Tank Drain Hose .....	23
Batteries .....	7	Deck Skirt Removal .....	23
Operator Responsibility .....	7	In-Line Solution Filter Assembly .....	24
<b>Machine Overview</b> .....	<b>8</b>	Rear Squeegee .....	25
Front .....	8	Cleaning the Squeegee .....	25
Rear .....	9	Changing the Squeegee Blades .....	25
Controls .....	10	Adjusting the Squeegee Blades .....	26
Bail Handle .....	11	Angle Adjustment .....	26
Handle Adjustment Knobs .....	11	Adjusting the Squeegee Blades .....	27
Key Switch .....	11	Height Adjustment .....	27
Direction Switch .....	11	<b>The E20 SPORT</b> .....	<b>28</b>
Squeegee Lift Lever .....	11	<b>Machine Operation</b> .....	<b>30</b>
Solution Control Lever .....	11	Turn on Machine .....	30
Battery / Fault Gauge .....	11	Turn on Vacuum .....	30
Speed Control .....	11	Turn on Brush Motor .....	30
Charge Status Indicator .....	11	Turn on Cleaning Solution .....	30
Brush Speed Keyswitch & Circuit Breakers .....	12	Direction Switch .....	30
Aqua-Saver Solution Control .....	13	Speed control .....	30
Battery Compartment .....	14	Driving .....	30
Diagnostic Code Guide .....	15	Charging the Batteries .....	31
Optional Hour Meter .....	16	Solution Solenoid .....	31
Brush Pressure Adjustment .....	17	Hour Meter (Optional) .....	31
Handle Adjustment .....	18	Loading Brush .....	32
Angle Adjustment .....	18	Unloading Brush .....	33
Horizontal Adjustment .....	19	<b>Maintenance</b> .....	<b>34</b>
Solution Tank Drain Hose .....	20	<b>Troubleshooting</b> .....	<b>36</b>
Solution Level Indicator .....	20	<b>WARRANTY</b> .....	<b>42</b>

### IMPORTANT SAFETY INSTRUCTIONS

Operators must read and understand this manual before operating or maintaining this machine.

Do not operate this machine in flammable or explosive areas.

This machine is designed solely for scrubbing dirt and dust in an indoor environment. Minuteman does not recommend using this machine in any other capacity.

The following information below may cause a potential hazard to the operator and equipment. Read this manual carefully and be aware when these conditions can exist. Take necessary steps to locate all safety devices on the machine and train the personnel operating the machine. Report any machine damage or faulty operation immediately. **Do not use machine if it is not in proper operating condition.**

### FOR SAFETY DURING OPERATION

Keep hands and feet clear of moving parts while machine is in operation.

Make sure all safety devices are in place and operate properly. All covers, doors and latches must be closed and fastened before use. During operation, attention should be paid to other persons in the work area and especially if small children are present.

Electric motors and components can cause an explosion when operated near explosive materials or vapor. Do not operate this machine near flammable materials such as solvents, thinners, fuels, grain dust, etc.

Store or park this machine on a level surface only. To prevent unauthorized use, machine should be stored or parked with the key removed.

This machine is designed for level operation only. **Do not operate on ramps or inclines greater than 2%.**

This machine is not suitable for picking up hazardous dusts.

Use caution when moving this machine into areas that are below freezing temperatures. Any water in the tanks or hoses can cause damage to the machine.

### FOR SAFETY WHEN SERVICING or MAINTAINING MACHINE

Stop on level surface.

Disconnect the power to the machine by unplugging the red Battery connector located under the recovery tank near the batteries.

Avoid moving parts. Do not wear loose jackets, shirts, or sleeves when working on machine.

Avoid contact with battery acid. Battery acid can cause burns. When working on or around batteries, wear protective clothing and safety glasses. Remove metal jewelry. Do not lay tools or metal objects on top of batteries.

Charging batteries generates explosive gasses.

**Do not charge batteries when open flames or sparks are present. Do not smoke.**

Make sure the charger is turned off before disconnecting it from the machine.

Charge the batteries in a well-ventilated area with the battery cover removed completely.

Do not clean machine with a pressure washer.

Authorized personnel must perform repairs and maintenance. Use Minuteman supplied replacement parts.

### SAVE THESE INSTRUCTIONS

### Inspection

Carefully unpack and inspect your **E20 SPORT Walk-Behind Scrubber** for shipping damage. Follow unpacking instructions on shipping pallet. Each unit has been tested and thoroughly inspected before shipment. Any damage is the responsibility of the delivery carrier who should be notified immediately.

### Electrical

This machine is battery operated and designed to operate on 24 volts DC (2) 12-volt batteries.

### Batteries

The recommended batteries are rated 140Ah WET (Minuteman P/N 956140) or 140Ah Maintenance free GEL (Minuteman P/N 956135). We do not recommend mixing AMP hour capacities. Alternate battery sets can be used if they equal physical size and capacity. If alternate battery sets are used please contact Minuteman for on board charger settings.

### Operator Responsibility

Read this manual carefully before operating this machine.

The operator is responsible for taking care of the daily maintenance and check ups of the machine to keep it in good working condition. The operator must inform the service mechanic or supervisor when the scheduled maintenance intervals are required as stated in the *MAINTENANCE* section of this manual.

Before starting familiarize yourself with the machine and its controls (see "Machine Overview, Front", "Machine Overview, Rear", "Control Console" diagrams).

## Machine Overview

### Machine Overview - Front

- A CUP HOLDER
- B SOLUTION FILL PORT
- C RECOVERY TANK LID
- D RECOVERY TANK
- E BRUSH DECK
- F FRONT WHEEL
- G REAR CASTER
- H SOLUTION TANK
- J FLOATING DECK SKIRT



**172520-8 Surface Prep Pads are thin:  
Always stack 2 pads together on Pad Driver**



## Machine Overview - Rear

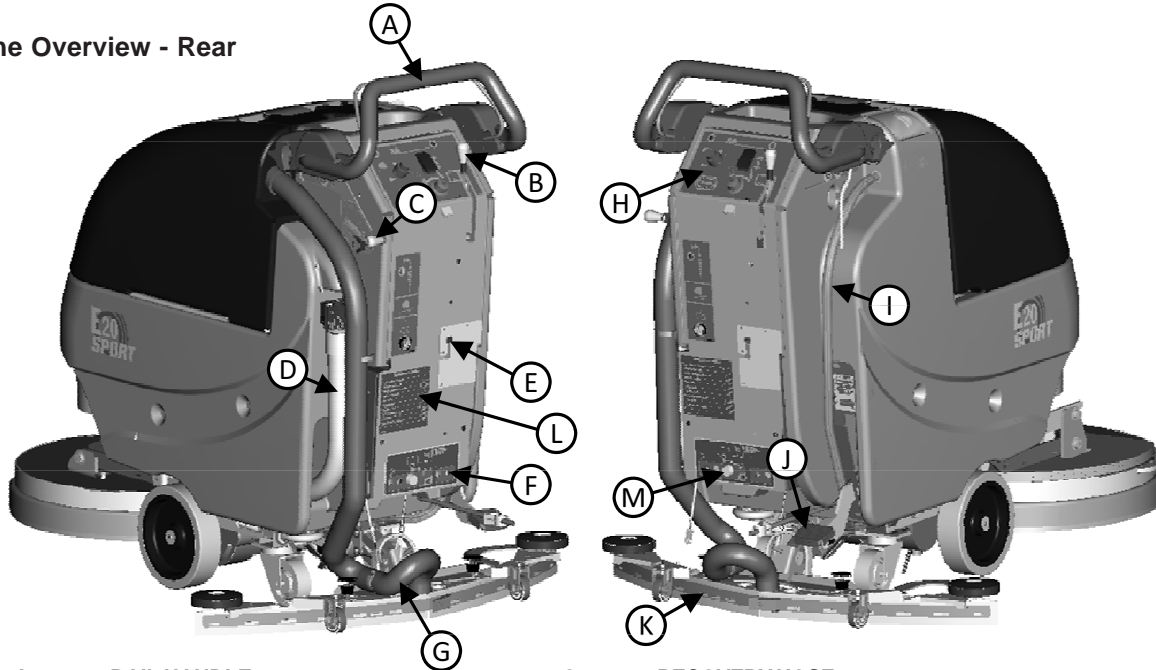

- A BAIL HANDLE
- B SQUEEGEE LIFT LEVER
- C SOLUTION CONTROL LEVER
- D RECOVERY TANK DRAIN HOSE
- E ONBOARD CHARGER CORD
- F CIRCUIT BREAKERS

- G RECOVERY HOSE
- H CONTROL PANEL
- I SOLUTION TANK DRAIN HOSE / LEVEL INDICATOR
- J BRUSH LIFT PEDAL
- K REAR SQUEEGEE
- L DIAGNOSTIC CODE GUIDE
- M BRUSH SWITCH KEYSWITCH & LED

### Controls

- A BAIL HANDLE
- B HANDLE ADJUSTMENT KNOB
- C KEY SWITCH
- D DIRECTION SWITCH
- E SQUEEGEE LIFT LEVER
- F BATTERY / FAULT GAUGE
- G SPEED CONTROL
- H CHARGE STATUS INDICATOR
- J SOLUTION CONTROL LEVER
- K AQUA-SAVER SOLUTION SETTING

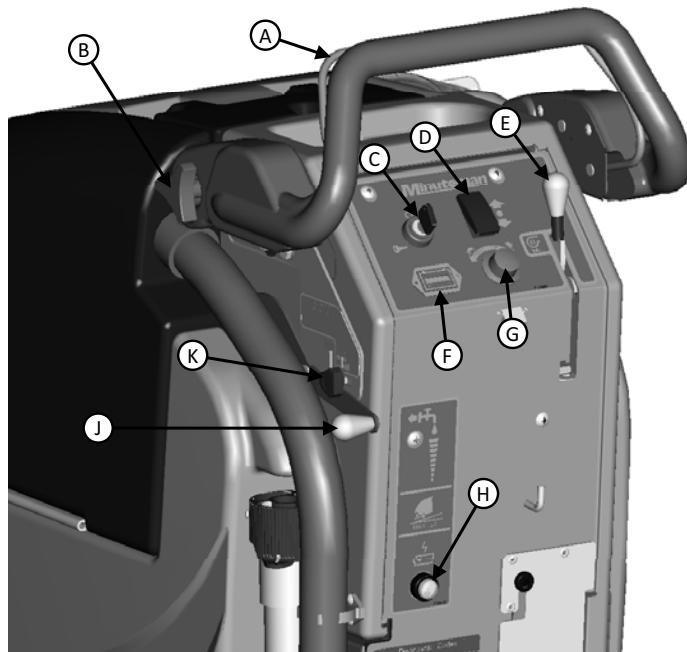

### **Bail Handle**

**(A)** When the scrub deck is lowered to the floor, the bail handle enables the brush motor and moves the machine forward once depressed. This also allows the operator to automatically load the brush when the scrub deck is lowered.

### **Handle Adjustment Knobs**

**(B)** Allows the handle position to be raised or lowered.

### **Key Switch**

**(C)** Controls the machine's power (Brush Unload/Off/On) with a key for safety. This switch, when turned counter clockwise, operates the auto brush unload when scrub deck is in the raised position. When it is turned to the on position, the machine will operate.

### **Direction Switch**

**(D)** This switch sets the direction the machine will move when the bail handle is pulled.

### **Squeegee Lift Lever**

**(E)** When actuated to the top position, the squeegee is lowered and the vacuum motor is turned on. When locked in the bottom position, the squeegee is raised and the vacuum motor shuts off after a 10 second delay.

### **Solution Control Lever**

**(F)** This lever controls the rate at which solution is put down. Moving the lever up will increase the amount of solution. Moving the lever down will decrease the solution rate. Moving the lever all the way down shuts off solution flow.

### **Battery / Fault Gauge**

**(G)** This gauge displays the remaining battery charge. This gauge also displays any fault codes that might occur with the Drive Motor Controller (see Diagnostic Codes).

### **Speed Control**

**(H)** This control sets the speed at which the machine will move.

### **Charge Status Indicator**

**(I)** This gauge displays the status of the batteries during charging. The gauge has a readout of 3 LEDs. 1 Green, 1 yellow, 1 Red. Green indicating a full charge, Yellow indicating 80% charged, Red indicating the batteries are charging.

### Brush Speed Keyswitch & Circuit Breakers

The circuit breakers are located at the bottom of the back panel of the machine.

- A** Main Control Circuit Breaker - 4A
- B** Brush Motor Circuit Breaker - 30A
- C** Vacuum Motor Circuit Breaker - 20A
- D** Drive Motor Circuit Breaker - 20A

If any of the functions above are not operating, check if the circuit breaker buttons have tripped. Press to reset.

- E** Brush Speed Keyswitch
- F** High RPM LED Indicator

When the key is turned to the right, the brush will rotate at high speed and the LED will illuminate.

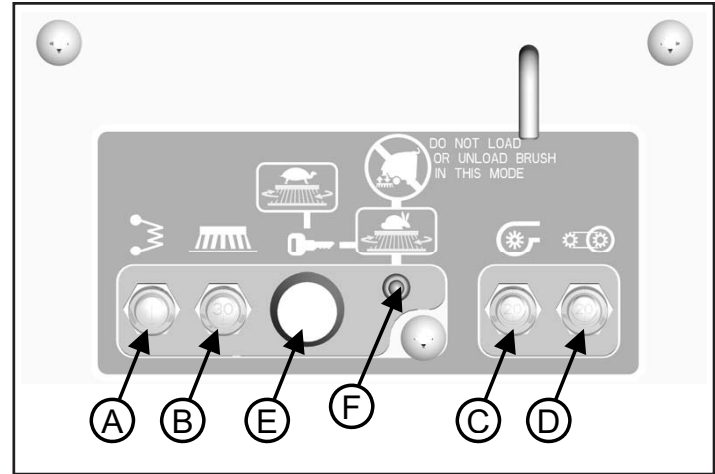

**The low speed is for standard cleaning with or without the brush deck weights.  
The high speed is for stripping, polishing and special cleaning processes.**

**NOTE: DO NOT LOAD OR UNLOAD BRUSH FROM MACHINE WITH LED LIT.  
DAMAGE TO BRUSH OR BRUSH MOTOR HUB MAY OCCUR.**

## Aqua-Saver Solution Control

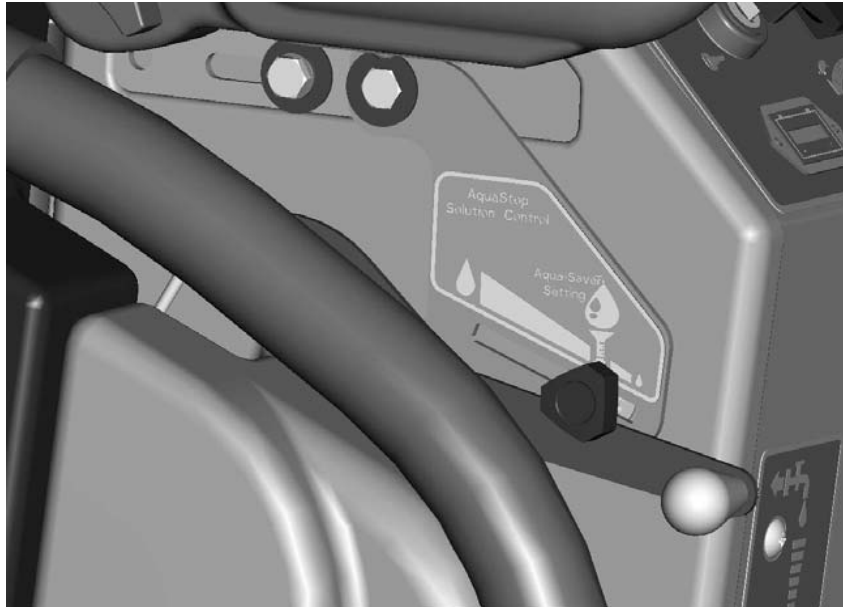

In order to consistently conserve water when using Aquastop brushes, the guide will stop the solution control lever at a low rate setting. This setting may be adjusted by loosening the knob, adjusting the lever, and retightening the knob. Slide the knob all the way forward to dispense maximum solution.

### Battery Compartment

The battery compartment is located under the recovery tank. The Battery compartment can be accessed for servicing and maintenance by tilting the recovery tank (make sure recovery tank has been drained before tilting). The battery compartment contains two 12-volt batteries connected in series. Connect the batteries according to the battery connection diagram (see *diagram*). The recommended batteries are 140Ah (Minuteman P/N 956140) or 100Ah (minuteman P/N 956100) Gel. The battery tray may be drained if necessary using the orange drain hose located above the rear caster on the right side of the machine.

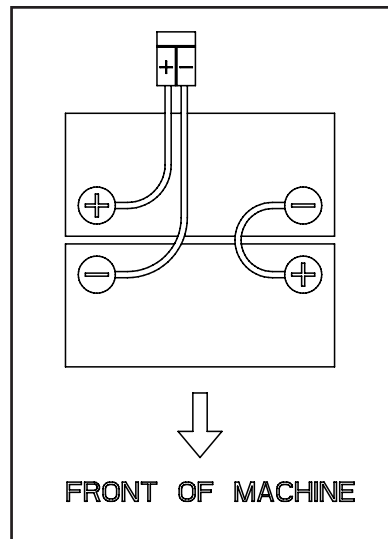

## Diagnostic Code Guide

When an error or fault occurs within the machine, a fault code will appear on the battery gauge represented by a specified number of flashing LEDs. (See “Troubleshooting” for further information)

## Diagnostic Codes

*The number of flashing bars on the battery gauge represent fault codes as indicated below:*

<b>Low Battery Voltage</b> <i>Check condition of battery and connections</i>	<b>1</b>
<b>Drive Motor Fault</b> <i>Check all connections between the motor and controller</i>	<b>2</b>
<b>Drive Motor Short Circuit</b> <i>Motor has a short circuit to a battery connection. Contact Service Agent</i>	<b>3</b>
<b>Battery Lockout</b> <i>Battery voltage is too low, controller is preventing function. Charge Batteries</i>	<b>4</b>
<b>Not Used</b>	<b>5</b>
<b>Drive Inhibit</b> <i>Check battery charger, drive is inhibited when plugged in</i>	<b>6</b>
<b>Throttle fault</b> <i>Restart keyswitch-bail handle was activated prior to turning machine on</i>	<b>7</b>
<b>Drive Controller Fault</b> <i>Check all connections are secure</i>	<b>8</b>
<b>Not Used</b>	<b>9</b>
<b>High battery voltage</b> <i>Check condition of battery and connections</i>	<b>10</b>

### Optional Hour Meter

Minuteman offers an optional hour meter for this machine. The optional kit replaces the power cord mounting bracket at the rear of the machine with one that contains an hour meter, which records the brush motor operating time.

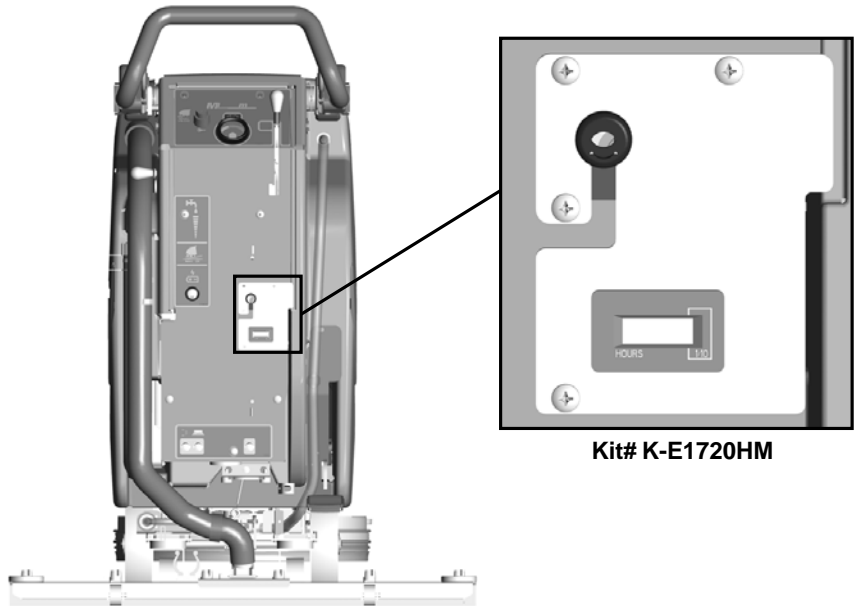



### Brush Pressure Adjustment

- One or both of the 10 lb. weight plates may be removed from the brush deck for best performance in different applications.
- Remove the 2 wing nuts on either side of the motor.
- With the brush deck lowered to the floor, lift the weight(s) plate up and off.
- Install wing nuts back onto the brush deck, store plate in a convenient location.
- When using 1 weight plate, move all 6 spacer-washers under the rear wing nut.

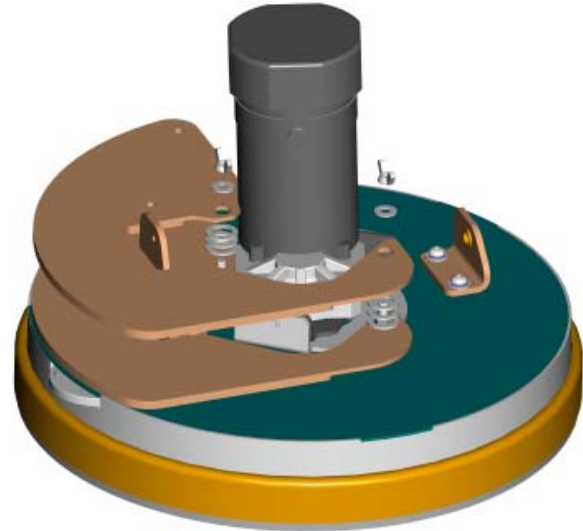

### Handle Adjustment

The handle was designed with operator comfort in mind. The angle and horizontal position of the handle can be adjusted to suit the needs of the operator.

### Angle Adjustment

The handle angle can be adjusted without tools by loosening the **Angle Adjustment Knob (A)** on each side and rotating the handle to the desired position. There are 5 angular positions  $11.25^\circ$  apart for a total of  $45^\circ$  between the minimum and maximum position.

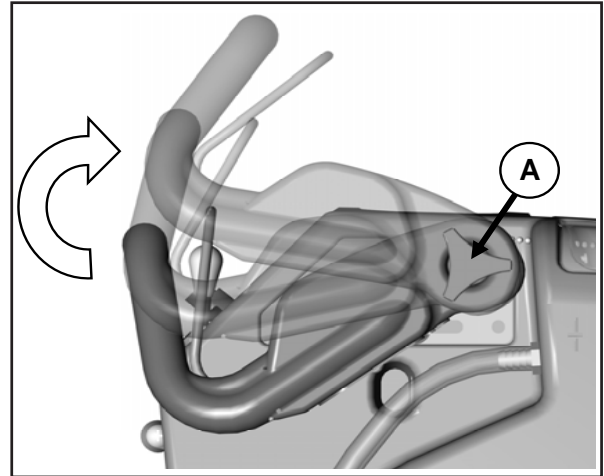

## Horizontal Adjustment

The horizontal position can be adjusted by removing the 4 **Mounting Bolts (B)** (2 each side) with a 9/16" socket and sliding the **Mounting Plate (P)** to one of the 3 available positions. The machine is shipped from the factory in position 1.

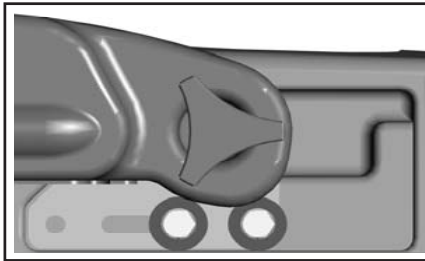
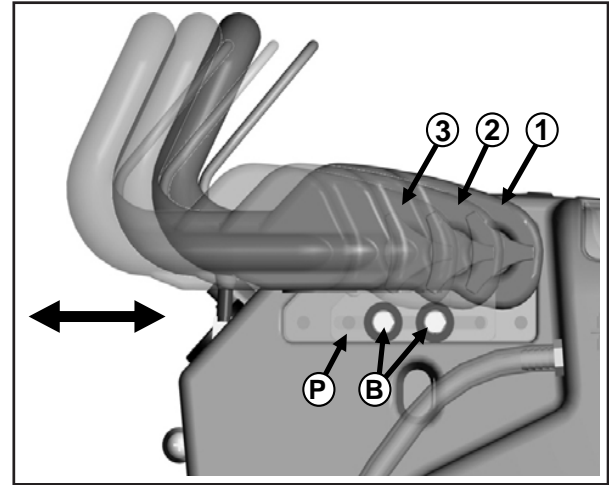

**Plate Position 3  
(Fully Extended)**

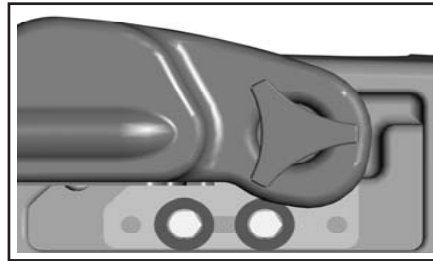

**Plate Position 2**

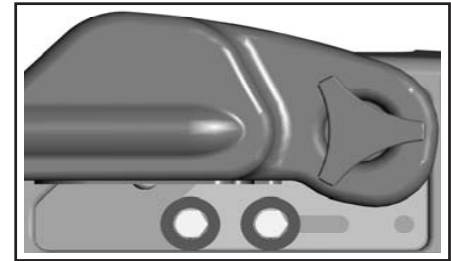

**Plate Position 1  
(Shipping Position)**

### Solution Tank Drain Hose

The solution tank may be drained by removing the **Solution Tank Drain Hose (A)** from the **Hose Barb (B)** and routing the hose to a floor drain.

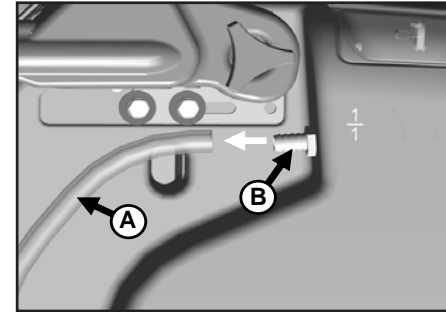
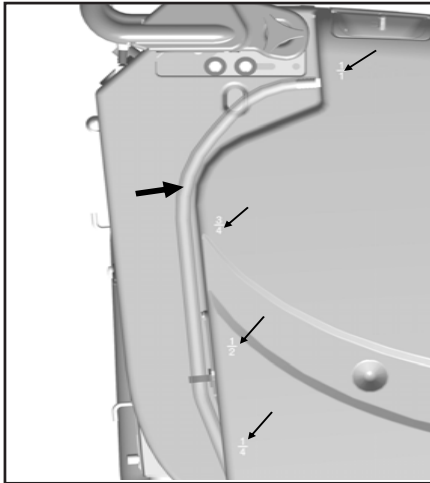

### Solution Level Indicator

The Solution Tank Drain Hose also serves as a water level indicator for the solution tank. The amount of water remaining in the solution tank can be seen through the clear drain hose. Level markers molded into the solution tank are positioned at 1/4, 1/2, 3/4, and full levels.

### Solution Fill Filter

The **Solution Fill Filter (B)** should be cleaned regularly. To remove, simply open the **Solution Tank Lid (A)** and pull the filter out.

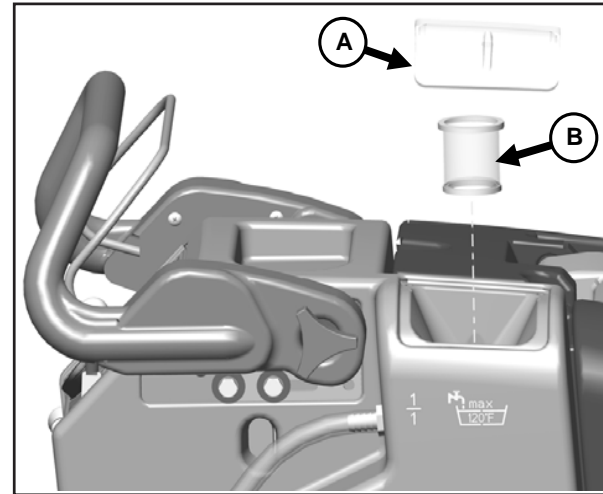

## Machine Overview

### Screened Float

If the recovery tank (C) is overfilled or a large amount of foaming is present, the screened float (B) blocks the vacuum intake inside the tank protecting the vacuum motor and internal electronics from water damage. It is essential to keep the float in working order through regular maintenance.

The float should be cleaned daily by thoroughly rinsing with a hose. Removal of the screened float is not necessary for daily maintenance.

At least once a month the screened float should be completely removed, cleaned, and checked for any damage to the seal or metal screen.

**WARNING:** Damage to the machine may occur if operated without the screened float properly in place.

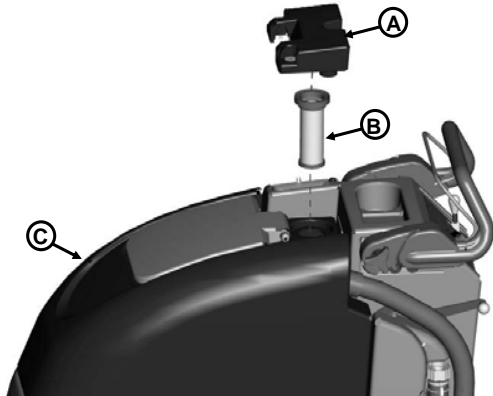

- A Vacuum Manifold
- B Screened Float
- C Recovery Tank
- D 1.5" Bolt
- E 1.25" Bolt (2)
- F Helical Washer (3)
- G Flat Washer (3)

### Screened Float Removal

The screened float is positioned between the vacuum manifold (A) and recovery tank (C). The screened float (B) can be accessed by removing the 1.5" bolt (D) and two 1.25" bolts (E) that attach the manifold to the recovery tank using a 7/16" socket.

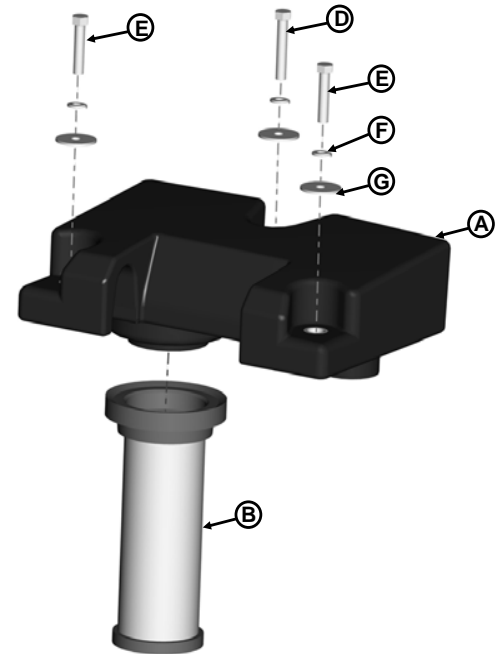

### Recovery Tank Drain Hose

Twist Cap to Open and Drain



Twist & Lift cap to clean out large debris



### Deck Skirt Removal

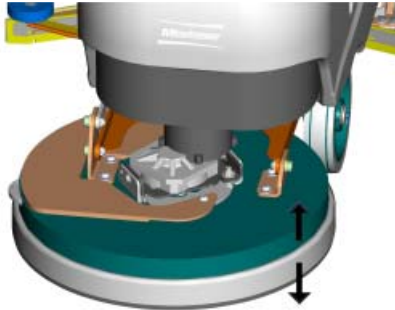

Brush Deck Skirt will ride on the floor in use and float up or down based on amount of pad/brush remaining.

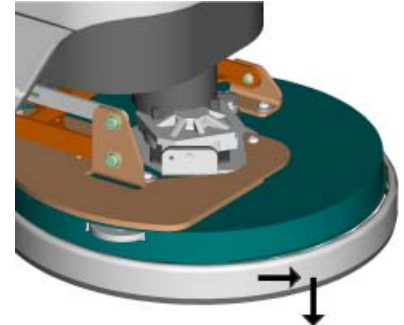

With brush removed & deck raised, Remove skirt for cleaning by pulling forward, then down over the edge of the deck.

### In-Line Solution Filter Assembly

The solution solenoid, which shuts off solution flow when the bail handle is released, is protected from debris by the in-line filter assembly. The filter assembly is located at the rear of the machine on the left hand side, just under the solution tank. It is important to check and clean the screened washer inside the assembly regularly to ensure proper solution flow. To open, unscrew the assembly (Note that the cone of the washer is facing out toward the rear of the machine). Remove washer and rinse, reinsert and screw assembly together, tightening by hand. **Overtightening with tools may damage the plastic threads.**

- A      Fitting, MGHT
- B      Screened Washer
- C      Hose Barb Insert
- D      Fitting, FGHT

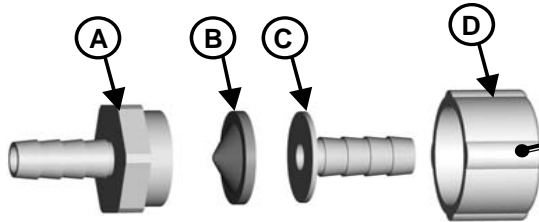



## Rear Squeegee

- A Squeegee
- B Star-shaped knob
- C Adjusting screw for angle adjustment
- D Suction hose
- E Blade fastening latch
- F Washers for caster height adjustment
- G Caster Wheel Axle

## Cleaning the Squeegee

Check the squeegee **(A)** daily and clean as necessary.

1. Pull off the suction hose **(D)**.
2. loosen the two star-shaped knobs **(B)**.
3. Remove the squeegee **(A)**.

## Changing the Squeegee Blades

Check the inner and outer squeegee blades on the squeegee **(A)** weekly for signs of wear. The squeegee blades can be reused by turning them (can be turned for 4 total uses).

1. Pull off the suction hose **(D)**, loosen the two star-shaped knobs **(B)** and remove the squeegee.
2. Unlock the fastening device **(E)** and remove the outer squeegee blade. Turn the squeegee blade or install a new one, as necessary. Change the inner squeegee blade in the same way.

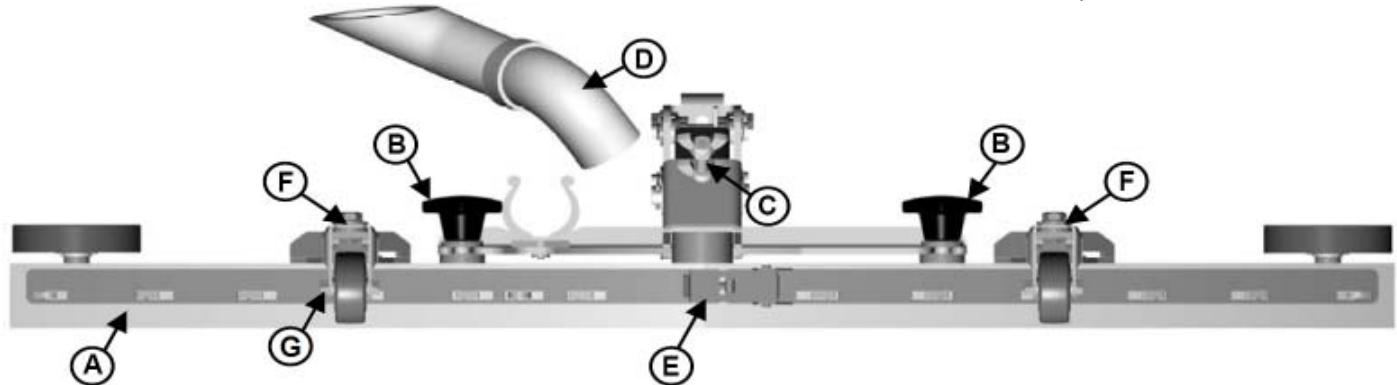

### Adjusting the Squeegee Blades Angle Adjustment

The angle adjustment is the decisive factor in ensuring that the squeegee blades on the squeegee lie evenly on the floor.

1. Park the machine on a level surface and lower the squeegee.
2. Loosen the lower wing nut (**B**) on the adjusting screw (**C**) and adjust the squeegee using the adjusting screw so that the ends of the squeegee blades still have contact with the floor. By turning the adjusting screw (**C**) counterclockwise, the clearance between squeegee blade and floor is **increased** in the center (Fig. 1). When turning the adjusting screw (**C**) clockwise, the clearance between squeegee blade and floor is **reduced** in the center (Fig. 2).
3. Switch the machine on and check the suction pattern. When the machine is in operation, the entire surface of the squeegee blades (center and outer areas) must be applied as evenly as possible.
4. Tighten the lower wing nut (**B**) on the adjusting screw (**C**) against the metal bracket to lock in the pitch setting.

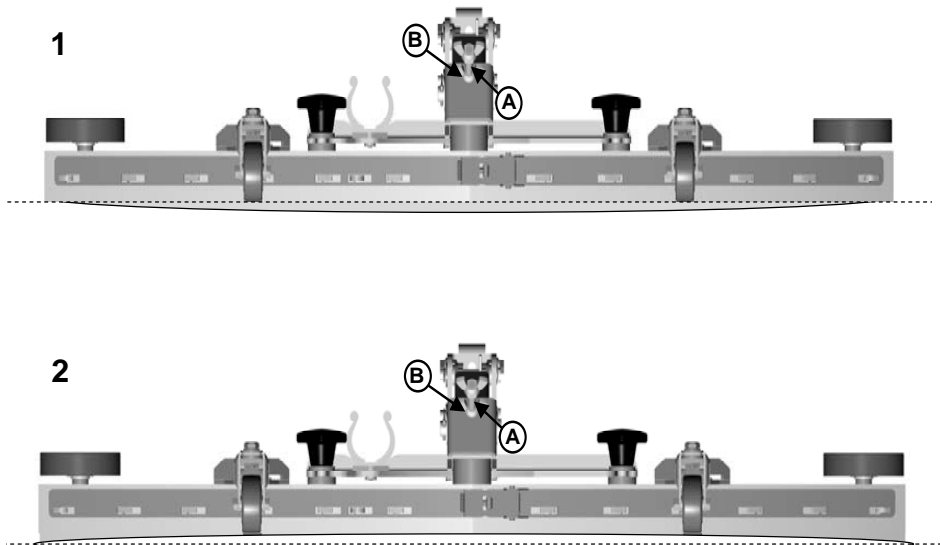

## Adjusting the Squeegee Blades Height Adjustment

If streaks are present, despite an optimum angle adjustment, the clearance between the caster wheels and floor must be adjusted by changing the number of washers underneath the bracket that holds the wheel. The squeegee height is preset at the factory to 2mm.

In cases of uneven smooth floors, e.g. grouted tile, etc., see 3mm illustration for washer configuration.

In cases of very uneven floors, e.g. poorly laid tiles (water does not run off) ,, configure as shown in 4mm illustration.



Keep the extra washers by installing them above the bracket as shown.

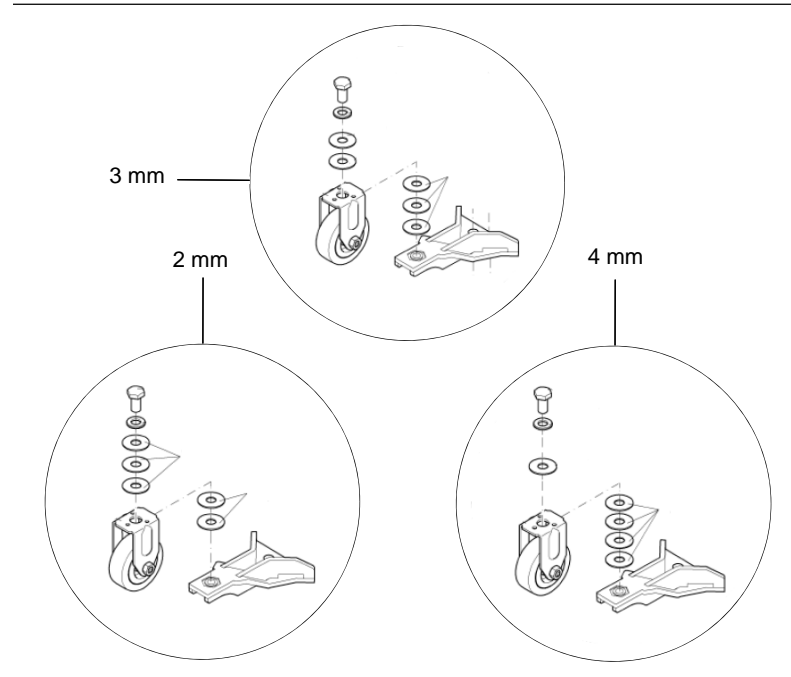

### The E20 SPORT

This machine was designed with total operator comfort and ease of use in mind. All machine components have been designed as a total system to efficiently clean dirty floors. The E20 SPORT has two available scrub head types and sizes to fit specific applications. *Please contact your Minuteman representative for specific recommendations for the correct scrub head type, size, and brush type and chemical applications.*

Before using the machine, always perform the following steps to ensure proper machine operation:

- Check under the machine for leaks.
- Check the rear squeegee for wear and damage.
- Check the solution and recovery tank levels.

After using the machine, always perform the following steps:

- Check the battery charge level. Charge batteries if necessary. When charging batteries, extra precaution is required:
  - Battery acid can cause burns.
  - When working on or around batteries, always wear protective clothing and safety glasses.
  - Remove metal jewelry. Do not lay tools or metal objects on top of the batteries.
  - Charging batteries generate explosive gasses.

**DO NOT CHARGE BATTERIES WHEN OPEN FLAMES OR SPARKS ARE PRESENT. DO NOT SMOKE.**

- Charge the batteries in a well-ventilated area.
- Fluid levels should be checked before and after charging and maintained at the proper levels. If low, add distilled water until the metal plates are covered.
- If the machine is not used for an extended period of time, batteries should be kept fully charged with a boost charge once a week.
- Check for wire, string, or twine wrapped around the scrub brushes.
- Check the rear squeegee for wear and damage.
- Check the rear squeegee suction hose for obstructions.
- Drain and clean the recovery tank and drain hose cap.
- Check under the machine for leaks.
- Check the service records to determine maintenance requirements.

**WARNING!**

- Be sure you understand the machine controls and their functions.
- While on ramps or inclines, avoid sudden stops when tanks are filled.
- Avoid abrupt sharp turns. Slow down driving speed when going downhill.

### **Turn on Machine**

Turn key to operate position ( I ). Wait for battery gauge to stop flashing. (If flashing continues, see troubleshooting guide)

### **Turn on Vacuum**

Lower squeegee into operating position, depress operator bail handle.

### **Turn on Brush Motor**

Select normal or high speed RPM w/key, next to circuit breakers. Lower the scrub deck to the floor by moving the brush lift pedal from the “home” (down) position to the operating position (up). Depress the operator bail handle.

### **Turn on Cleaning Solution**

Move solution lever from closed (down) position up to the desired flow position. With the scrub deck on the floor, depress the bail handle, solution will begin to flow.

Note: The solution solenoid will stop solution flow whenever the bail handle is released.

### **Direction Switch**

Select direction of machine by moving the directional rocker switch from the neutral position to the forward or reverse position. The direction of the machine movement is shown on the operator panel with forward and reverse arrows.

### **Speed control**

Move the speed dial to the desired position. Turning the dial clockwise increases the speed. Turning the dial counterclockwise decreases the speed. When dial is all the way counter-clockwise, machine will not move.

### **Driving**

Depress the operator bail handle, the machine will move in the direction selected.

### Charging the Batteries

When the battery status indicator reaches the red zone the batteries need to be recharged. Take the machine to a well ventilated area, unwind the battery charger power cord from the electrical box cover and plug into an appropriate power source. After approximately 10 seconds the battery charge status indicator will turn on. Be sure to check the battery water levels as recommended.

**WARNING: Charging batteries generates explosive gasses. Do not charge batteries when open flames or sparks are present. Do not smoke. Charge the batteries in a well-ventilated area.**

### Solution Solenoid

Water solenoid will operate when the brush motor is turned on. The solution lever must be moved to the desired operating position, but does not need to be moved to the closed position when stopping for brief periods.

### Hour Meter (Optional)

Hour meter will automatically record operating time of the brush motor.

### Loading Brush

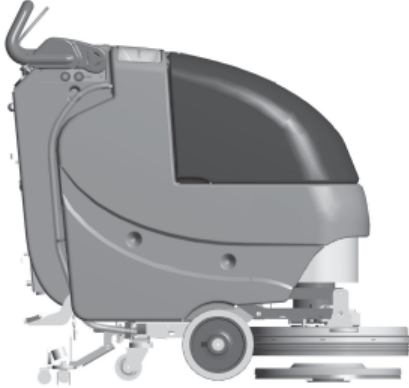

1. To load the brush, first center the E20 brush deck over the scrub brush.

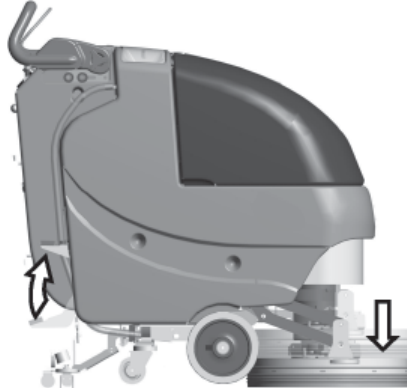

2. Lower the scrub deck by releasing the deck lift pedal.



3. With the key turned on, pull the bail handle to engage the scrub brush onto the scrub deck.

**NOTE: DO NOT LOAD BRUSH FROM MACHINE WITH BRUSH SPEED LED LIT (HIGH SPEED).  
DAMAGE TO BRUSH OR BRUSH MOTOR HUB MAY OCCUR.**



## Unloading Brush

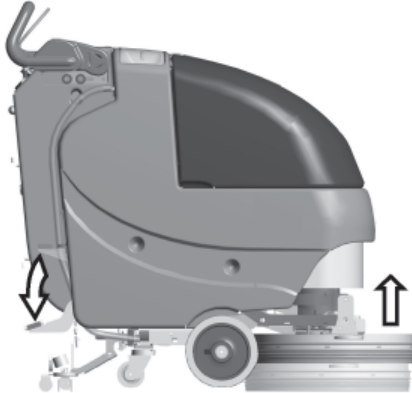

1. To unload the brush, first lift the scrub deck by pressing down on the deck lift pedal. Make sure the pedal is in the "home" position shown below.



2. Turn the key for **5 seconds** to the "Brush Unload" position then let the key return to the off (O) position.

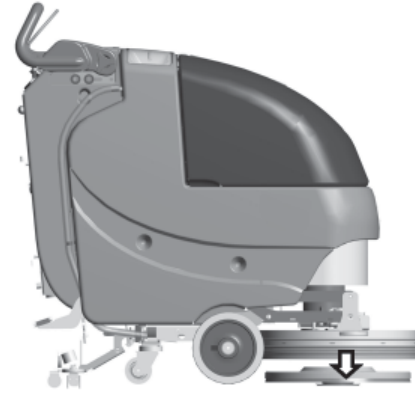

3. After key returns to off (o) position, brush will release from the scrub deck and fall to the floor.

**CAUTION: Make sure scrub deck is clear of all personnel and obstructions before operating Brush Unload.**

### After Use

1. When finished scrubbing, lift the scrub deck and turn the solution lever off. Lift the rear squeegee (the vacuum motor will turn off after 10 seconds). Move the machine to a service area for daily maintenance and review items that may need service.
2. Empty the solution tank by disconnecting the **solution tank drain hose** from the barb fitting and routing hose to a drain. Rinse the tank with clean water to prevent any buildup of dried chemicals that could clog the plumbing inside the recovery tank, and the drain hose cap.
3. Empty and clean the recovery tank by flushing with a hose. Be sure to also clean the float shut off screen.
4. Remove the **brushes** or pad holders and rinse them in warm water and hang to dry.
5. Remove the **rear squeegee**, rinse with warm water and reinstall after cleaning.
6. Check the **maintenance schedule** in the next section and perform any required maintenance before storing the machine.
7. Store the machine indoors in a clean dry place. Keep from freezing. Leave solution and recovery tank lids open for ventilation to prevent odor buildup.
8. Turn **Key switch OFF (O)** and remove key.

Daily	Weekly	Monthly	Yearly
Charge Batteries	Check Each Battery Cell(s) Water Level	Lubrication – Grease Fittings	Check Carbon Brushes
Check/Clean Tanks & Hoses	Inspect/Clean Scrub Deck Skirt for Debris		
Check/Clean the Brush/Pad	Inspect and Clean In-Line Solution Filter		
Check/Clean the Squeegee			
Check/Clean Vacuum Shut-Off Float in Recovery Tank			

Have a qualified service technician check the vacuum motor carbon motor brushes once a year or after 300 operating hours. The brush motor and transaxle motor carbon brushes should be checked every 500 hours or once a year.

**NOTE:** Refer to the Service Manual for more detail on maintenance and service repairs.

Regularly scheduled lubrication of certain machine parts should be performed to insure trouble-free operation of the machine. *Apply a generous amount of grease into the fittings on the rear caster swivel (2) until grease seeps out around the bearings.*

*Apply lubricant or light machine oil to lubricate the:*

- *Pivot mounting point of the rear squeegee to the chassis (1)*
- *Rear squeegee caster wheel axle (2)*

Problem	Possible Cause	Remedy
<b>Poor water pick-up</b>	Worn or torn squeegee blades	Rotate or replace blades
	Recovery tank full	Empty recovery tank
	Recovery tank drain hose leak	Secure drain hose cap, replace o-ring in cap if damaged
	Recovery tank lid gasket leak	Replace gasket lid cover properly
	Debris caught in squeegee	Clean squeegee
	Using too much solution	Adjust solution control valve
	Recovery hose clogged, damaged, or disconnected at tank or squeegee	Remove debris and flush hose, reconnect or replace
<b>Poor scrubbing performance</b>	Worn brush / pad	Replace brush / pad
	Wrong brush or cleaning chemical	Consult Minuteman
	Debris caught on brush / pad	Remove debris
	Moving machine too fast	Use slower speed
	Not using enough solution	Adjust solution flow setting
<b>Inadequate solution flow or no solution to the floor</b>	Low battery charge	Recharge batteries
	Solution tank empty	Fill solution tank
	Solution lines, valve, filter clogged	Flush lines, and clean solution filter.
<b>Machine does not move</b>	Solution Lever in down position	Move lever up
	Directional switch in neutral position	Activate switch in FWD or REV position
	Squeegee is down and directional switch is in reverse position	Raise squeegee when in reverse mode
	Traction drive circuit breaker has tripped	Reset circuit breaker
	Batteries lost power	Recharge batteries

Problem	Possible Cause	Remedy
<b>Machine does not operate</b>	Tripped Control Power circuit breaker	Reset breaker
	Batteries have low charge	Recharge batteries
	Battery charger operating	Unplug battery charger when charge is complete
	Key switch off	Turn key on
	Bail handle depressed too quickly after turning key on	Turn key off, turn on, wait until battery gauge lights up without flashing
<b>Vacuum motor does not turn on</b>	Bail handle is not depressed	Bail Handle must be depressed
	Recovery tank full	Empty recovery tank
	Excessive foaming in recovery tank.	Use less or change chemical. Use defoaming agent.
	Squeegee in raised position	Lower squeegee
	Tripped vacuum motor circuit breaker	Reset breaker
	Broken vacuum limit switch	Replace switch
	Carbon Brushes worn	Replace carbon brushes
Vacuum switch disconnected	Connect wiring	
<b>Brush does not unload</b>	Foot pedal not in "home" position	Place pedal in notch
	Tripped brush motor circuit breaker	Reset breaker
	Broken brush motor switch	Replace switch near the pedal
	Damaged brush block or drive hub	Inspect for cracks & replace
<b>Batteries do not charge</b>	Charger not plugged to wall outlet	Plug into wall outlet
	Circuit breaker tripped in wall outlet	Reset breaker
	Battery disconnected from machine	Fix connections to batteries
	Charger malfunction	Call service

<b>Charger Warning Indicators</b>		
	<b>LED Status</b>	<b>Description</b>
Warning	<b>RED LED lamp blink once</b>	Output open circuit or short circuit or reverse polarity connection of charger to battery. Battery voltage is too high (may be connected to wrong voltage battery).
	<b>RED LED lamp blink twice</b>	Abnormal cycle (may be weak or bad battery) Charging time has safety timed out due to battery problem.

### Fault / Diagnostic Codes

The Battery / Fault gauge will flash when a fault is detected. A decal labeled “Diagnostic Codes” is located below the battery gauge as an abbreviated and convenient guide to determine the cause of the fault and the remedy (refer to machine or see “Diagnostic Code Guide” section of this manual). The flashing codes are for the following:

#### 1 Bar



The battery needs charging, there is a bad connection to the battery or dependent on programming, may indicate that the battery lockout function is active and the controller is in a restricted mode of operation. Check the connections to the battery. If the connections are good, try charging the battery.

#### 3 Bar



The motor has a short circuit to a battery connection. Contact your service agent.

#### 2 Bar



There is a bad connection to the motor. Check all connections between the motor and the controller.

#### 4 Bar



The battery charge level has fallen below the Battery Lockout level and the controller is inhibiting certain machine functions. Charge the battery.



Not used.



A controller fault is indicated. Make sure that all connections are secure.

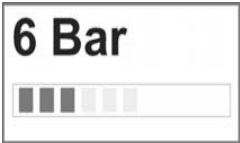

The controller is being inhibited from driving, this may be because the battery charger is connected.



Not used.

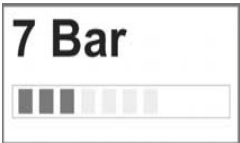

The bail handle was activated prior to turning the machine on. Make sure that the bail handle is in the rest position. Restart the key switch.



An excessive voltage has been applied to the controller. This is usually caused by a poor battery connection. Check the battery connections.







### Minuteman International Made Simple Commercial Limited Warranty

#### REVISION F EFFECTIVE 6/1/2009

Minuteman International, Inc. warrants to the original purchaser/user that the product is free from defects in workmanship and materials under normal use. Minuteman will, at its option, repair or replace without charge, parts that fail under normal use and service when operated and maintained in accordance with the applicable operation and instruction manuals. All warranty claims must be submitted through and approved by factory authorized repair stations.

This warranty does not apply to normal wear, or to items whose life is dependent on their use and care, such as belts, cords, switches, hoses, rubber parts, electrical motor components or adjustments. Parts manufactured by Minuteman are covered by and subject to the warranties and/or guarantees of their manufacturers. Please contact Minuteman for procedures in warranty claims against these manufacturers.

Special warning to purchaser — Use of replacement filters and/or prefilters not manufactured by Minuteman or its designated licensees, will void all warranties expressed or implied. A potential health hazard exists without original equipment replacement.

All warranted items become the sole property of Minuteman or its original manufacturer, whichever the case may be.

Minuteman disclaims any implied warranty, including the warranty of merchantability and the warranty of fitness for a particular purpose. Minuteman assumes no responsibility for any special, incidental or consequential damages.

This limited warranty is applicable only in the U.S.A. and Canada, and is extended only to the original user/purchaser of this product. Customers outside the U.S.A. and Canada should contact their local distributor for export warranty policies. Minuteman is not responsible for costs or repairs performed by persons other than those specifically authorized by Minuteman. This warranty does not apply to damage from transportation, alterations by unauthorized persons, misuse or abuse of the equipment, use of non-compatible chemicals, or damage to property, or loss of income due to malfunctions of the product.

If a difficulty develops with this machine, you should contact the dealer from whom it was purchased.

This warranty gives you specific legal rights, and you may have other rights which vary from state to state. Some states do not allow the exclusion or limitation of special, incidental or consequential damages, or limitations on how long an implied warranty lasts, so the above exclusions and limitations may not apply to you.

**Cord Electric Group: Three years parts, two years labor, ninety days travel (Not to exceed two hours)**

**Exceptions.....**

<u>Model</u>	<u>Parts</u>	<u>Labor</u>	<u>Poly</u>	<u>Travel</u>
Port A Scrub	1 yr	6 months	10 yrs	0
MPV 13	1 yr	0	0	0
MPV 14 & 18	2 yrs	1 yr	0	0
V Series Upright Vacuums	1 yr	1yr	0	0
Rapid Air Blower	1 yr	1 yr	10 yrs	0
Explosion Proof Vacuum	1 yr	1 yr	0	0
X12, X12H & TRS 14	1 yr	1 yr	10 yrs	0
E17 & E20 Electric Scrubbers	1 yr	6 months	10 yrs	0
Pneumatic Vacuums	3 yr	1 yr	0	0

<u>Description</u>	<u>Parts</u>	<u>Labor</u>	<u>Poly</u>	<u>Travel</u>
Battery Operated Group	3 yrs	2 yrs	10	90 days
Sweepers	1 yr	1 yr	10	90 days
Internal Combustion Group	1 yr	1 yr	10	90 days

Not to exceed two hours

**Exception: PAS 14B**                      **1 yr**                      **1 yr**                      **10 yr**                      **0**

**Battery Chargers:**

**One year replacement**

Replacement Parts:

Ninety days

Batteries:

0-3 months replacement, 4-12 months pro-rate

Polyethylene Plastic Tanks:

Tanks have 10yr warranty, no additional labor

Minuteman International, Inc.  
14N845 U.S. Route 20 · Pingree Grove, Illinois 60140 USA  
Phone 800-323-9420 · Fax 800-422-6933  
[www.minutemanintl.com](http://www.minutemanintl.com)  
***A Member of the Hako Group***

**988721UMS**  
**Rev A 06/12**